

MeshAP™ 3800

Outdoor

Triple 5GHz/Single 2.4GHz

Full-Duplex

Mobile Mesh Technology

Wireless Access Point



Reliable, Intelligent, High Performance Mesh Network

- Patent pending, auto-discovery, auto-configure, real-time routing, and auto-healing POP (Predictable Optimum Path) mesh routing algorithm
- Real-time mesh routing based on monitoring current environment, product function change and administrator bandwidth adjustment needs
- Multiple wireless path design for both backhaul and user traffic eliminates adjacent AP signal interference and provides zero performance degradation
- Best network throughput via layer 2 fast switching and bridging from AP to AP to support real time video, voice, and data applications
- Up to 16 separate SSID/VLAN with different authentication and encryption algorithms simultaneously

Fully Compatible with Existing Access Servers, Routers, and Gateways

- Transparent to layer 3 and up protocols, fully compatible with existing network equipment
- Directly connects to existing Routers, Gateways, or APs through 10/100 Ethernet

Management and Security

- Supports SNMP v2c & Web Based browser
- Supports WEP encryption security across wireless mesh network
- Mesh network protection with user defined Mesh ID
- WPA/WPA2 Security protection for the backhaul network.

ArrowSpan Inc.

4800 Great America Parkway
Suite 238
Santa Clara, CA 95054
www.arrowspan.com

Providing City-Wide Wi-Fi access to any community large or small. The Metro MeshAP 3800 provides users with a dependable flexible network, and at the same time improves city-wide productivity, increases safety and encourages economic development. ArrowSpan's MeshAP 3800 provides Wi-Fi access using wireless mesh technology with plug-n-play easy installation, and allows carriers and service providers to deliver a true wireless network over large geographical areas or other locations where wiring is too difficult or expensive to install.

A Mesh Link is a true wireless connection (Point-to-multipoint, and Point-to-point) between any two MeshAP units. ArrowSpan MeshAP 3800 will automatically discover its neighboring MeshAP 3800 and interconnect all the MeshAP units together to form a large coverage wireless network.

MeshAP 3800 implements Layer 2 mesh routing which provides excellent network performance and is fully compatible with existing network equipment and applications. The MeshAP 3800 is able to support high-bandwidth and low latency applications like real-time video and voice.

Predictable Real-time Optimum Path (POP) routing algorithm creates a MeshAP 3800 based Wi-Fi mesh network with the best throughput, reliable mesh link, and self-discovery/self-configuration/self-healing benefits. The algorithm's human-like intelligence examines the network and makes appropriate connections among MeshAPs in real time. It also re-establishes a new network when obstacles, individual node problems, new nodes or internet access events occur.

High throughput Mesh Network is achieved by a non-blocking and no-interference design for client and backhaul traffic. The MeshAP 3800 multi-radio and multi-channel architecture eliminates the wireless signal interference and traffic conflict problems that exist on many other mesh network products.

SNMP v2c and web-based (HTML) management interface enables both professional and non-technical users to easily handle network management and maintenance tasks for the MeshAP units. The "Point and Click" browser interface permits users to monitor node condition, link quality, traffic flow, and event logs of the MeshAP units on the mesh network. The web-based Topology function also allows Network administrators to easily configure, update, and monitor every MeshAP station on the mesh network. SNMP private MIBs are available for advanced users preferring to manage through their own network manager.

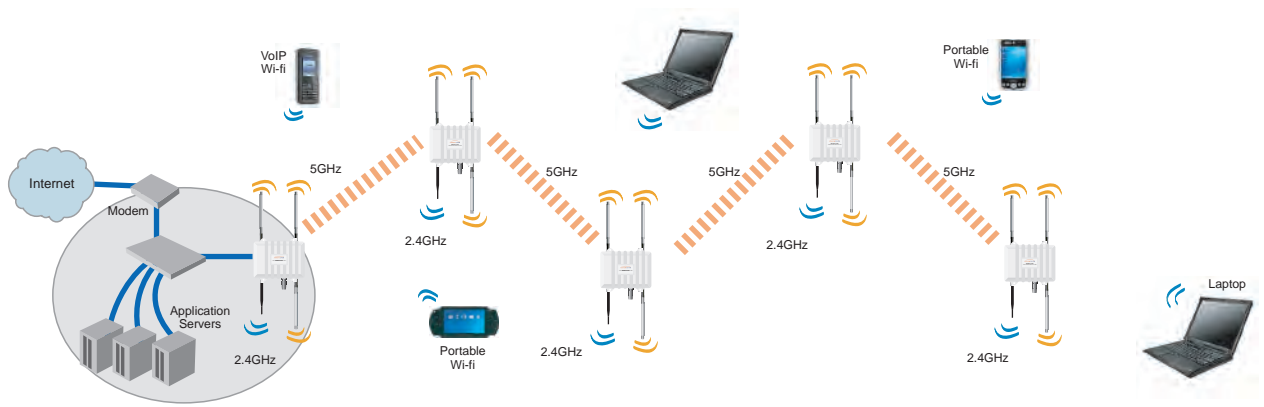

Specifications

Wireless

Backhaul Mesh Radio

Number of Radio: 3
Frequency: 5.8GHz/5.4GHz/5.3GHz/4.9GHz ISM radio band
Frequency Bands: 4.9 - 5.091 GHz
 5.470 - 5.725 GHz, 5.725 - 5.850 GHz
Modulation: OFDM(64-QAM, 16-QAM, QPSK, BPSK)
Data Rates:** 6, 9, 12, 18, 24, 36, 48, 54Mbps
Tx Radio Power*: up to 27dBm (avg)

Receiving Sensitivity:
 -82dBm @36Mbps; -78dBm @48Mbps; -76dBm @54Mbps

Antenna & Connector:
 (3x) 8dbi 5GHz omni directional antenna
 (3x) N-type outdoor waterproof connector

AP (Access Point) Radio

Number of Radio: 1
Standards: IEEE 802.11g, 802.11b
Media Access Protocol: CSMA/CA with ACK
Frequency: 2.4GHz ISM radio band
Frequency Bands: 2.4 - 2.462 GHz
Modulation:
 802.11g - OFDM(64-QAM, 16-QAM, QPSK, BPSK)
 802.11b - CCK(11, 5.5MHz), DOPSK(2Mbps), DQPSK(1Mbps)

Data Rates:
 802.11g: 6, 9, 12, 18, 24, 36, 48, 54Mbps
 802.11b: 1, 2, 5.5, 11Mbps

Tx Radio Power*: 2.4GHz: up to 27dBm (avg)

Receiving Sensitivity:
 -82dBm @36Mbps; -78dBm @48Mbps; -76dBm @54Mbps

Channels:
 802.11g - USA, Canada, Saudi Arabia, Taiwan: 11
 Most European countries, China: 13
 France: 4
 Japan: 14
 802.11b - USA, Canada, Saudi Arabia, Taiwan: 11
 Most European countries: 13
 France: 4
 Japan: 14

Antenna & Connector:
 (1x) 8dbi 2.4GHz omni directional antenna
 (1x) N-type outdoor waterproof connector

Mesh Backhaul Performance

Up to 30Mbps mesh backhaul throughput at the 5th hop count

Operating Range

Mesh Backhaul: Node-to-node Distance: 304m(1000ft)@54Mbps
802.11bg AP:
 150m(492ft)@54Mbps
 500m(1640ft)@6Mbps

*Note: (1). Actual Txpower dBm depends on regulatin and product model.
 (2). Transmission speed vs. distance may vary according to the environment, government regulation, and product model.

Software Feature

Security & Encryption

64bit, 128bit WEP encryption (Hardware Accelerated)
 WPA/WPA-2 (Hardware Accelerated, 128bit AES)
 Radius support
 Multi-level Mesh operator username/password
 Mesh ID protection
 MAC based filter

AP Features

Up to 16 separate SSID/VLAN
 WMM
 AP user privacy across whole mesh network
 QOS
 SSID Broadcast enable/disable
 AP setting synchronization to Mesh Manager control
 Syn/non-Syn SSID field
 User MAC list, SNR, Tx/Rx count, Error count
 Auto-channel assignment

Backhaul Mesh RF Control

Tx Power Control - Settable Tx levels to adjust coverage cell size
 Automatic / Manual Channel Selection
 Automatic / Manual Mesh node selection
 Self-discovering / Self-configuring / Self-routing / Self-healing Mesh Link
 Real time mesh routing
 Mesh Link quality diagnostic tool

Management

Web based (HTML) Management
 SNMP v2c, Private MIB
 Topology and log
 Fail-safe IP
 Fail-safe BSSID
 DHCP Client IP
 NTP time server
 IP based router alive detection
 Remote software upgrade
 Software RESET button to factory default

Hardware Specification

Network Port

(1) 10/100Mbps auto crossover Ethernet WAN Port, waterproof connector

Power

Power Interface: POE
 Input: 48VDC 380mA

Environment Conditions

Operating Temperature: -40°F to 131°F (-40°C to 55°C)
 Storage Temperature: -50°F to 158°F (-58°C to 70°C)
 Humidity: 95% maximum relative humidity, non-condensing

Physical Specifications

Dimension: 23.4cm x 17cm x 6.3cm
 Weight: 1.5kg

Enclosure

Rating: IP66 water proof
 Vertical/Horizontal mounting kit

Regulatory Compliance

Certification: FCC Part 15
 (Please contact ArrowSpan for other Certifications)